

NJP372 Series

■ Features

- 3.5 φ
- CTIA / OMTP Compliance

- Lead Free
- HF
- RoHS



NEW

Rating	DC12V 1A max.
Contact Resistance	100mΩ max.
Insulation Resistance	DC500V -100MΩ min.
Withstand Voltage	AC500V - 1 minute
Insertion Force	0.4 ~ 2.0 Kgf
Extraction Force	0.3 ~ 1.5 Kgf

Recommended Reflow Soldering Profile

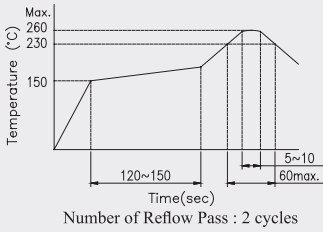

Recommended Manual Soldering Profile

	Temperature	Time
Manual Soldering Temperature	350 °C (max.)	3 Sec.(max.)

The solder iron and solder shall be applied at a distance of 1.91 mm to 2.54 mm from the plastic housing.

Durability	5,000 cycles
------------	--------------

■ SMT - D Type

12.5L x 6.8W x 4.1H

Product No.	Package
NJP372-103T	1,200 Pcs/Reel

■ Applicable Plug

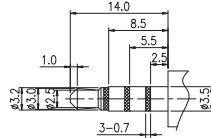

Schematic

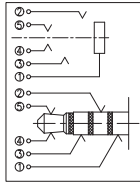

P.C.B Layout

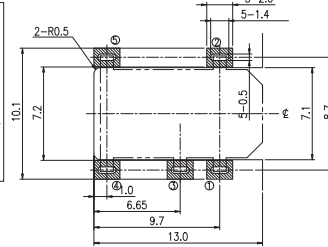

■ Outline Drawing

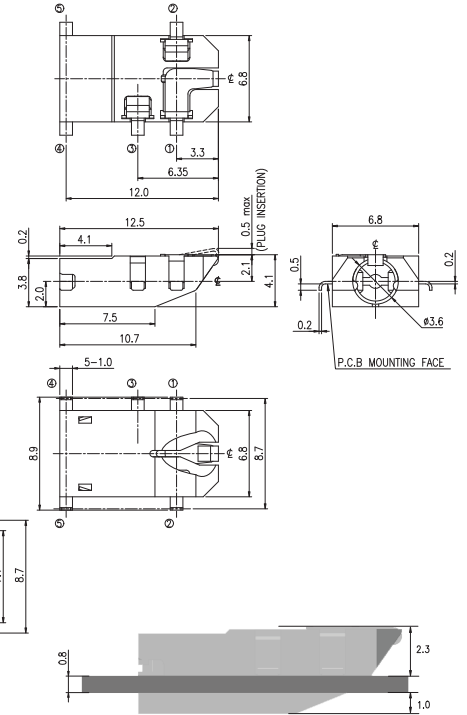

General Tolerance : ±0.2mm.