

# NJP369 Series

## Features

Lead Free    HF    RoHS

- 3.5 φ
- CTIA / OMTP Compliance



Rating	DC12V 1A max.
Contact Resistance	100mΩ max.
Insulation Resistance	DC500V -100MΩ min.
Withstand Voltage	AC500V - 1 minute
Insertion Force	0.4 ~ 2.0 Kgf
Extraction Force	0.3 ~ 1.5 Kgf

### Recommended Reflow Soldering Profile

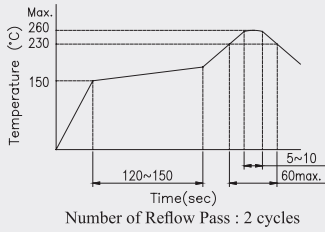

### Recommended Manual Soldering Profile

	Temperature	Time
Manual Soldering Temperature	350 °C (max.)	3 Sec.(max.)

The solder iron and solder shall be applied at a distance of 1.91 mm to 2.54 mm from the plastic housing.

Durability	5,000 cycles
------------	--------------

### SMT - D Type

12.5L x 6.8W x 4.1H

Product No.	Package
NJP369-101T	1,200 Pcs/Reel

### Applicable Plug

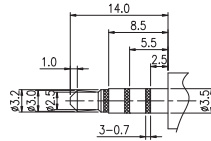

### Schematic

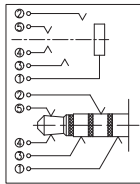

### P.C.B Layout

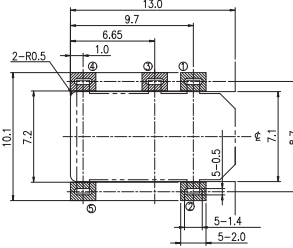

### Outline Drawing

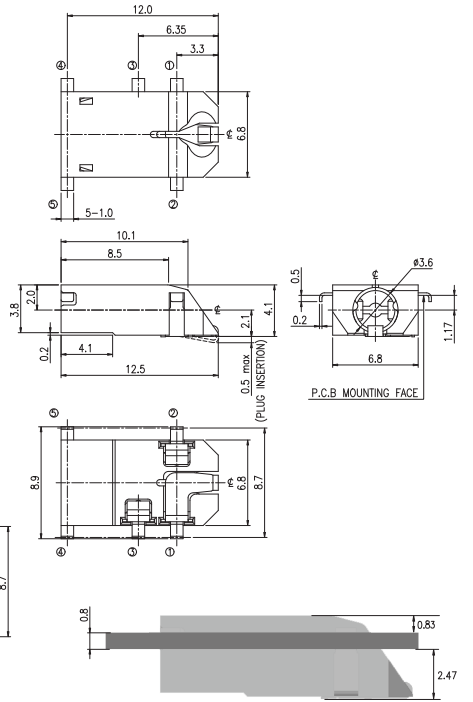

General Tolerance : ±0.2mm.